

HPS.05.218.100



SUZUKI XF650 Freewind

Hauptständer

Montagehinweise

Alle vom Motorrad gelösten Schrauben sind gemäß Herstellerangaben wieder zu montieren, oder mit von SW-MOTECH gelieferten Schrauben zu ersetzen. Falls nicht anderweitig definiert, diese Schrauben nach Tabelle anziehen.

M6	9,6 Nm
M8	23 Nm
M10	46 Nm

Gegebenenfalls Schrauben mit flüssiger Schraubensicherung einkleben.

Prüfen Sie nach 50km alle Verbindungen auf festen Sitz.

Die Kurvenfreiheit kann durch einen Hauptständer eingeschränkt werden

SW- MOTECH GmbH & Co. KG
 Bahnhofsstrasse 44d
 35282 Rauschenberg
 -Germany-

Tel.: ++ 49 (0) 6425 816 800

Fax: ++ 49 (0) 6425 816 810

www.sw-motech.com

Centre Stand

Mounting Instructions

Centerstand cornering clearance:

SW-MOTECH centerstands are carefully designed and tested to eliminate reductions in cornering clearance and ground clearance under most driving conditions on an unmodified stock motorcycle, and are certified to be compliant with European ABE safety standards. Use of any centerstand may reduce coming clearance or ground clearance under extreme driving situations.







SW-MOTECH products should be installed by a qualified, experienced motorcycle technician. If you are unsure of your ability to properly install a product, please have the product installed by your local motorcycle dealer. SW-MOTECH takes no responsibility for damages caused by improper installation.

All screws, bolts, and nuts, including all replacement hardware provided by SW-MOTECH, should be tightened to the torque specified in the OEM maintenance manual for your motorcycle. If no torque specifications are provided in the OEM maintenance manual, the following torques may be used:

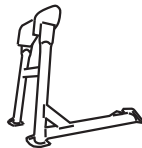
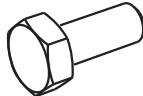
M6	9,6 Nm
M8	23 Nm
M10	46 Nm

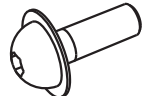
All screws, bolts, and nuts should be checked after driving the first 50 km to ensure that all are tightened to the proper torque.

Medium strength liquid thread-locker (i.e., "Locktite") should be used to secure all screws, bolts, and nuts.

<p>1 Hauptständer Centre Stand</p>  <p>HPS.05.218.900</p> <p>Anzahl/ Pcs. 1</p>	<p>2 Sechskantschraube Hexagon Screw</p>  <p>M10x1,25x50 DIN 961</p> <p>Anzahl/ Pcs. 2</p>	<p>6 Anschlag Stopper</p>  <p>HPS.05.218.002</p> <p>Anzahl/ Pcs. 1</p>
<p>3 Unterlegscheibe Washer</p>  <p>A 10,5 DIN 125</p> <p>Anzahl/ Pcs. 2</p>	<p>7 Linsenschraube Lenshead</p>  <p>M6 x 25 ISO 7380</p> <p>Anzahl/ Pcs. 2</p>	
<p>4 Distanzbuchse Spacer</p>  <p>HPS.05.218.001</p> <p>Anzahl/ Pcs. 2</p>	<p>8 Mutter mit Bund Nut</p>  <p>M 6 DIN 6927/b</p> <p>Anzahl/ Pcs. 2</p>	
<p>5 Zugfeder Spring</p>  <p>ZFD.00.150.007</p> <p>Anzahl/ Pcs. 1</p>	<p>9 Gummianschlag Rubber Element</p>  <p>MSS.00.003.016</p> <p>Anzahl/ Pcs. 1</p>	

! Achtung:
Die Kurven- und Bodenfreiheit kann durch einen Hauptständer eingeschränkt werden

Attention:
Cornering and ground clearance can be reduce by using a centre stand

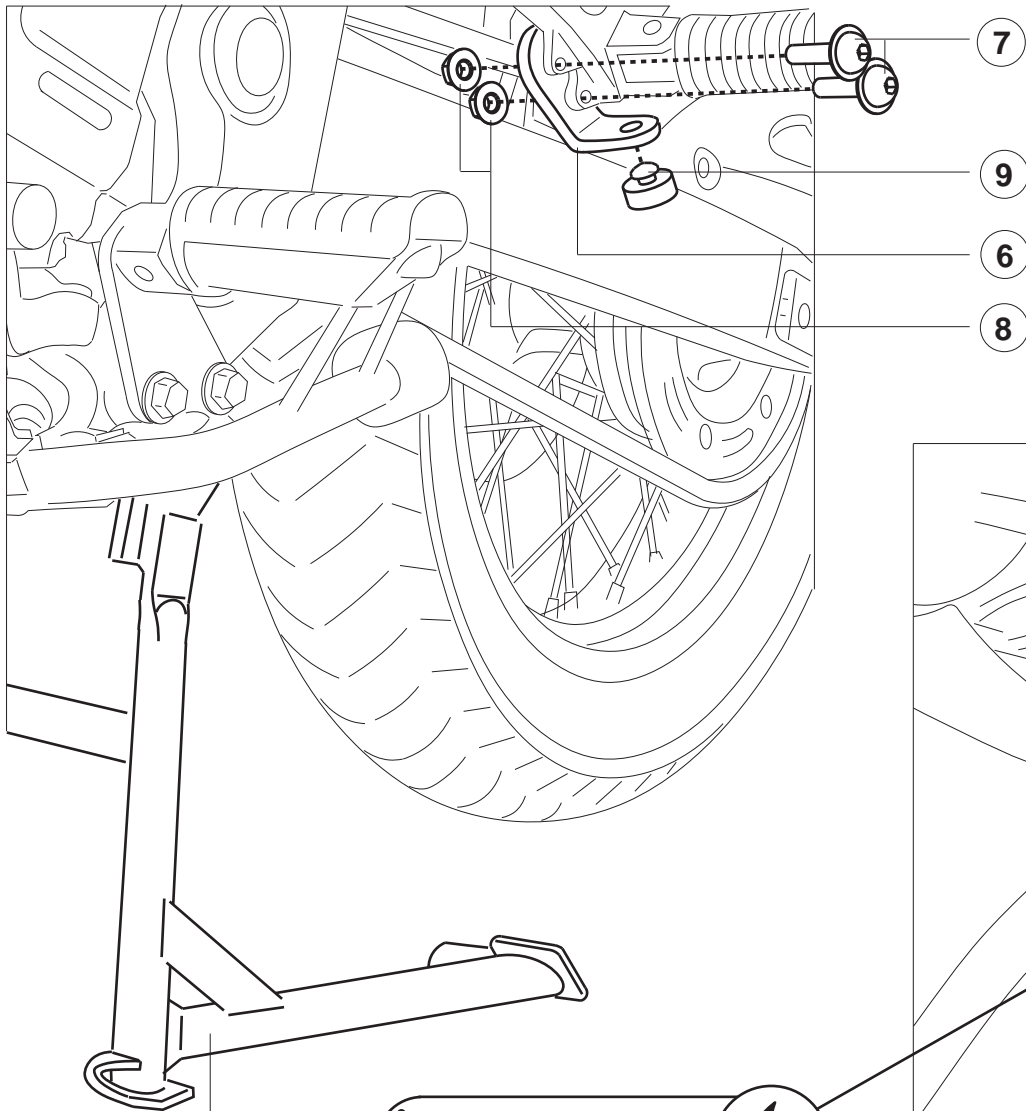

5 an Stehbolzen (am Rahmen) einhängen
fix on bolt (on frame)

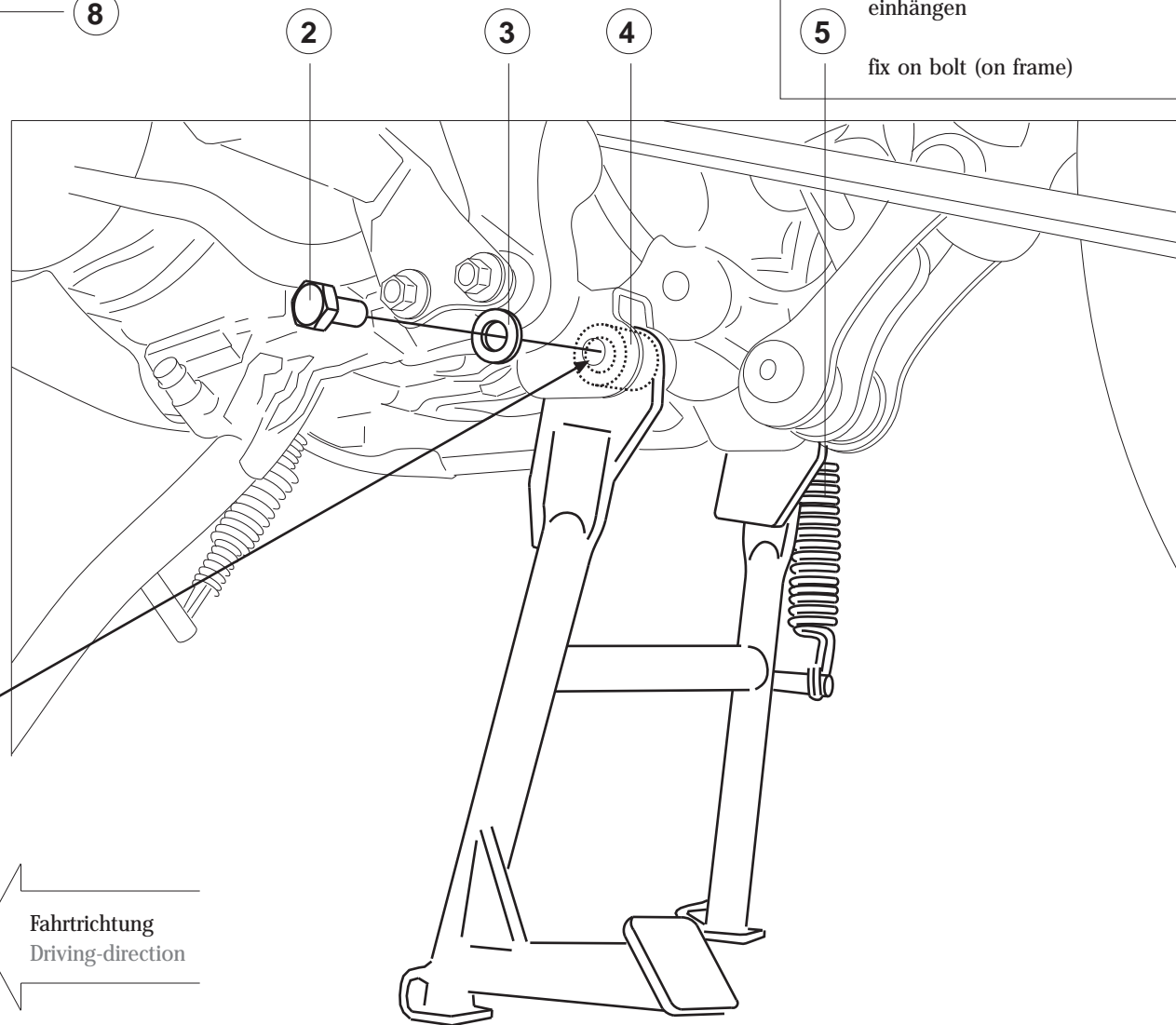

! Mit Fett einsetzen
Insert with grease

! Schraube (2) mit Schraubensicherung einsetzen
Insert screw (2) with retainer



1

7

9

6

8

2

3

4

5